

SRP-6PB SERIES 6 INCH 60 CELLS



260-275_w



ONLY FOR AUSTRALIA

MANAGEMENT SYSTEM

ISO 9001: Quality management system

ISO 14001: Standard for environmental management system

OHSAS 18001: International standard for occupational health and safety assessment system

PRODUCT CERTIFICATES

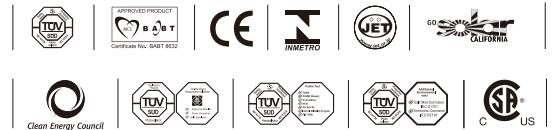

INSURANCE



WARRANTY

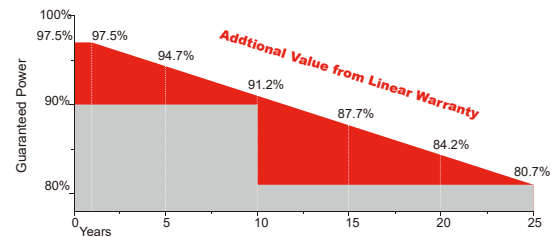

10 YEARS

Guarantee on product material and workmanship

25 YEARS

linear power output warranty

Safety



Safety for salt mist corrosion (IEC61701, tested in TÜV SÜD)



Safety for ammonia corrosion (IEC62716, tested in TÜV SÜD)



Safety for fire risk (Class C, tested in TÜV SÜD and Rheinland)

Reliability



PID free products, passing TÜV SÜD system voltage durability test



World 1st company to pass "Thresher Test" and "On-site Power Measurement Validation" certificate



Bankable products

Performance



Outstanding power output capability at low irradiance



Triple 100% Electroluminescence (EL) tests minimize breakage rate



Top rank in Photon yield measurement

Specifications are subject to change without further notification SRP-DS-EN-2017V1.0 © Copyright 2017 Seraphim

SRP-6PB SERIES 6 INCH 60 CELLS



DuraFlex™

*DURAFLEX™ PRODUCTS ARE AVAILABLE UPON REQUEST
*BLACK FRAME / BLACK BACK-SHEET PRODUCTS ARE AVAILABLE UPON REQUEST.

Electrical Characteristics (STC)

Module Type	SRP-260-6PB	SRP-265-6PB	SRP-270-6PB	SRP-275-6PB
Maximum Power at STC - P_{mp} (W)	260	265	270	275
Open Circuit Voltage - V_{oc} (V)	38	38.30	38.5	38.8
Short Circuit Current - I_{sc} (A)	8.72	8.83	8.94	9.02
Maximum Power Voltage - V_{mp} (V)	30.9	31.1	31.3	31.6
Maximum Power Current - I_{mp} (A)	8.42	8.53	8.63	8.71
Module Efficiency STC- η_m (%)	15.98	16.29	16.6	16.9

STC: Irradiance 1000 W/m² module temperature 25°C AM=1.5
Power measurement tolerance: +/-3%

Electrical Characteristics (NOCT)

Module Type	SRP-260-6PB	SRP-265-6PB	SRP-270-6PB	SRP-275-6PB
Maximum Power at NOCT - P_{mp} (W)	192	196	200	203
Open Circuit Voltage - V_{oc} (V)	35	35.3	35.5	35.7
Short Circuit Current - I_{sc} (A)	7.05	7.14	7.22	7.29
Maximum Power Voltage - V_{mp} (V)	28.8	29.1	29.3	29.5
Maximum Power Current - I_{mp} (A)	6.67	6.74	6.83	6.88

NOCT: Irradiance 800 W/m² ambient temperature 20°C wind speed :1m/s
Power measurement tolerance: +/-3%

Power Tolerance (W)	(0,+4.99)
Maximum System Voltage (V)	1000 (TÜV), 1000 (UL)
Maximum Series Fuse Rating (A)	15

Temperature Characteristics

Pmax Temperature Coefficient	-0.41 %/°C
Voc Temperature Coefficient	-0.32 %/°C
Isc Temperature Coefficient	+0.05 %/°C
Operating Temperature	-40~+85 °C
Nominal Operating Cell Temperature (NOCT)	45±2 °C

Packing Configuration

	1640 x 992 x 35mm	
Container	20'GP	40'GP
Pieces per Pallet	30	30
Pallets per Container	12	28
Pieces per Container	360	840

Mechanical Specifications

External Dimensions	1640 x 992 x 35 mm
Weight	18.5kg
Solar Cells	Poly crystalline 156.75 x 156.75 mm (60pcs)
Front Glass	3.2 mm tempered glass, low iron
Frame	Anodized aluminium alloy
Junction Box	IP67
Output Cables	4.0 mm ² ,cable length:900 mm
Connector	TL-CABLE01 / PV-TT01 / 05-6
Mechanical Load	5400 Pa

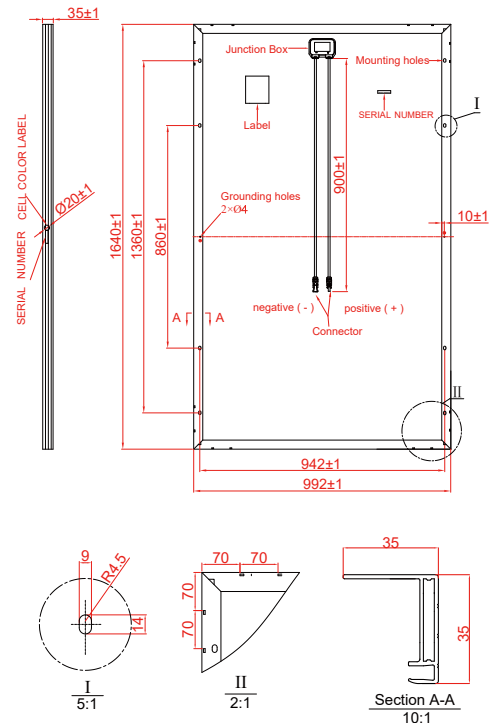

* All Dimensions in mm

* The above drawing is a graphical representation of the product.
For engineering quality drawings please contact SERAPHIM.

I-V Curve (SRP-260-6PB)

