



SunPower® E-Series Commercial Solar Panels | E20-327-COM

More than 20% Efficiency

Captures more sunlight and generates more power than conventional panels.

High Performance

Delivers excellent performance in real world conditions, such as high temperatures, clouds and low light.^{1,2,3}

Commercial Grade

Optimised to maximise returns and energy production, the E-Series panel is a bankable solution for commercial solar applications.



Maxeon™ Solar Cells: Fundamentally better.
Engineered for performance, designed for reliability.

Engineered for Peace of Mind

Designed to deliver consistent, trouble-free energy over a very long lifetime.^{4,5}

Designed for Reliability

The SunPower Maxeon Solar Cell is the only cell built on a solid copper foundation. Virtually impervious to the corrosion and cracking that degrade Conventional panels.⁴

#1 Rank in Fraunhofer durability test.¹⁰
100% power maintained in Atlas 25+ comprehensive Durability test.¹¹

High Performance & Excellent Reliability



SPR-E20-327-COM

High Efficiency⁶

Generate more energy per square meter

E-Series commercial panels convert more sunlight to electricity producing 36% more power per panel,¹ and 60% more energy per square meter over 25 years.^{3,4}

High Energy Production⁷

Produce more energy per rated watt

More energy to power your operations. High year one performance delivers 7-9% more energy per rated watt.³ This advantage increases over time, producing 20% more energy over the first 25 years to meet your needs.⁴

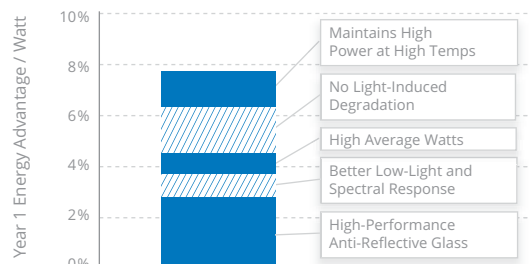
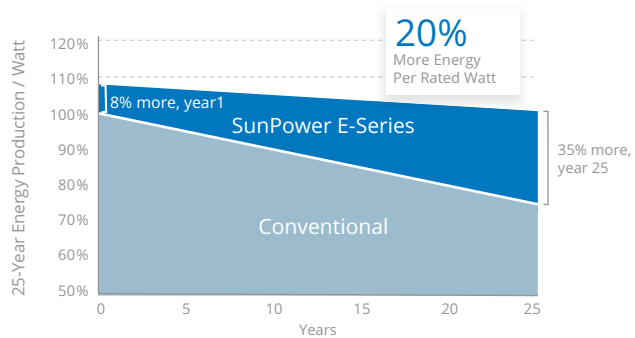

SunPower® E-Series Commercial Solar Panels | E20-327-COM

Sunpower Offers The Best Combined Power And Product Warranty

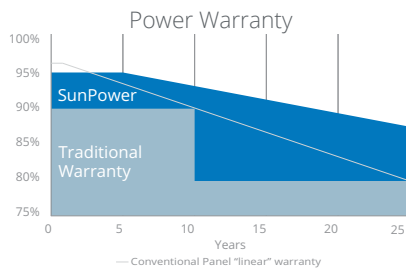

More guaranteed power: 95% for first 5 years, -0.4%/yr. to year 25.⁸

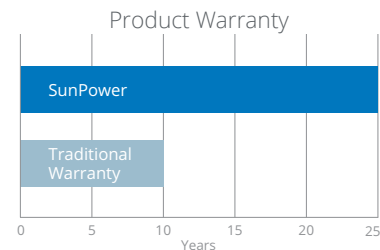

Combined Power and Product defect 25 year coverage that includes panel replacement costs.⁹

Electrical Data

	SPR-E20-327-COM	SPR-E19-310-COM
Nominal Power (P _{nom}) ¹²	327 W	310 W
Power Tolerance	+5/-3%	+5/-3%
Avg. Panel Efficiency ¹³	20.3%	19.3%
Rated Voltage (V _{mpp})	54.7 V	54.7 V
Rated Current (I _{mpp})	5.98 A	5.67 A
Open-Circuit Voltage (V _{oc})	64.9 V	64.4 V
Short-Circuit Current (I _{sc})	6.46 A	6.05 A
Max. System Voltage	1000 V IEC & 1000 V UL	
Maximum Series Fuse	15 A	
Power Temp Coef.	-0.38% / °C	
Voltage Temp Coef.	-176.6 mV / °C	
Current Temp Coef.	3.5 mA / °C	

Tests And Certifications

Standard tests ¹⁴	IEC 61215, IEC 61730, UL1703 (Type 2 Fire Rating)
Quality Certs	ISO 9001:2008, ISO 14001:2004
EHS Compliance	RoHS, OHSAS 18001:2007, lead free, PV Cycle, REACH SVHC-155
Ammonia test	IEC 62716
Desert test	10.1109/PVSC.2013.6744437
Salt Spray test	IEC 61701 (maximum severity)
PID test	Potential-Induced Degradation free: 1000V ¹⁰
Available listings	TUV, MCS, UL, JET, CSA, CEC, FSEC

Operating Condition And Mechanical Data

Temperature	-40°C to +85°C
Impact resistance	25mm diameter hail at 23 m/s
Appearance	Class B
Solar Cells	96 Monocrystalline Moxeon Gen II
Tempered Glass	High transmission tempered Anti-Reflective
Junction Box	IP-65 Rated, Tyco (PV4)
Weight	18,6 kg
Max load	Wind: 2400 Pa, 244 kg/m ² front & back Snow: 5400 Pa, 550 kg/m ² front
Frame	Class 2 silver anodised

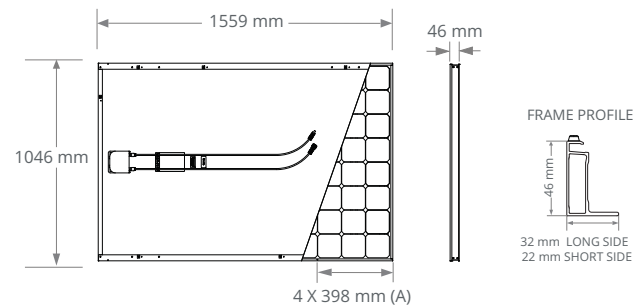

(A) Stacking Pins

Please read the safety and installation guide.

REFERENCES:

- All comparisons are SPR-E20-327 vs. a representative conventional panel: 250W, approx. 1.6 m², 15.3% efficiency.
- PVEvolution Labs "SunPower Shading Study," Feb 2013.
- Typically 7-9% more energy per watt, BEW/DNV Engineering "SunPower Yield Report," Jan 2013.
- SunPower 0.25%/yr degradation vs. 1.0%/yr conv. panel. Campeau, Z. et al. "SunPower Module Degradation Rate," SunPower white paper, Feb 2013; Jordan, Dirk "SunPower Test Report," NREL, Q4-2014.
- "SunPower Module 40-Year Useful Life" SunPower white paper, Feb 2013. Useful life is 99 out of 100 panels operating at more than 70% of rated power.
- Second highest, after SunPower X-Series, of over 3,200 silicon solar panels, Photon Module Survey, Feb 2014.
- 8% more energy than the average of the top 10 panel companies tested in 2012 (151 panels, 102 companies), Photon International, Feb 2013.
- Compared with the top 15 manufacturers. SunPower Warranty Review, Feb 2013.
- Some exclusions apply. See warranty for details.
- 5 of top 8 panel manufacturers from 2013 report were tested, 3 additional silicon solar panels for the 2014. Ferrara, C., et al. "Fraunhofer PV Durability Initiative for Solar Modules: Part 2". Photovoltaics International, 77-85. 2014.
- Compared with the non-stress-tested control panel. Atlas 25+ Durability test report, Feb 2013.
- Standard Test Conditions (1000 W/m² irradiance, AM 1.5, 25° C). NREL calibration Standard: SOMS current, LACCS FF and Voltage.
- Based on average of measured power values during production.
- Type 2 fire rating per UL1703:2013, Class C fire rating per UL1703:2002.

See <http://www.sunpower.com/facts> for more reference information.
For more details, see extended datasheet: www.sunpower.com/datasheets.

Document # 505821 Rev B /A4_UK_AUS